

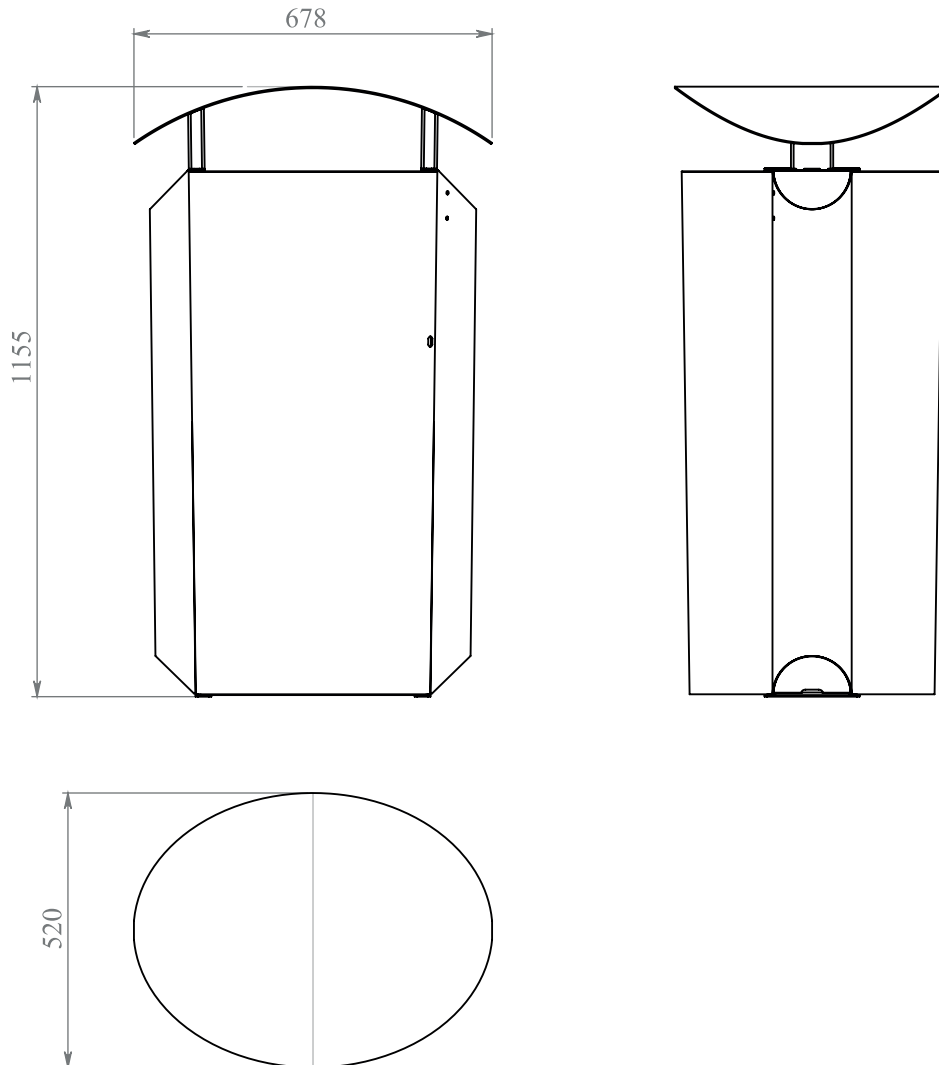

**Max Dimensions:**

Height: 1155 mm | Length: 678 mm | Depth: 520 mm

Capacity: 120 Lt

**Description:**

The load-bearing structure of the MASH bin is made in steel sheet of 30/10 thickness, on which two brackets of 30/10 thickness are welded. Two pins 6x20 mm are welded on the lower part on the left: one serves as a hinge and the other is meant for the fixing of the back of the bin. Only one pivot is welded on the plate of the right for the fixing of the back of the bin. The cover is the result of a calendered, oval-shaped sheet of 30/10 thickness. It is supported by 2 elements in steel of 30/10 thickness bent to shape 2 supports with section 30x80mm. The cover is fixed to the load-bearing structure of the bin through 4 screws M8 to be inserted on specific threaded inserts. The door and the back are made in steel sheet of 12/10 thickness and are reinforced internally with profiles of 30/10 thickness. The door is provided with a triangular key lock. Inside the bin there is a bag-holder, which is partially removable, made in steel sheet of 20/10 thickness. The sides of the bin are calendered with a 12/10 thickness. On the upper part of the right side, a plate provided with a pierced sheet (holes of 5 mm diam) is welded. It also has a central hole of 20 mm diam. to keep the ashes and the cigarette butts. Inside the bin, on the load-bearing structure, a cylindrical container made in galvanized steel of 8/10 thickness for the cigarette butts, is placed right where the hole of the right side is. The MASH bin is provided with a base in concrete.

For the realization of this product, Steel EN10111DD11 is used and later treated with a cycle of sandblasting, cathaphoresis and powder coating. Such cycle is meant to guarantee the protection of the painted products, in an environment of C4 corrosion class, as requested by the UNI regulations EN ISO 12944-2. The products are eventually polyester-powder coated with RAL colours at choice. The galvanized steel used is steel EN10346DX51D+Z and, unless otherwise stated, is not painted.