

“SQUARE” Litterbin

Sheet code: **CEAR015**

Drawing code:

Revision:

23/01/2019

Designer:

Bellitalia Design Department

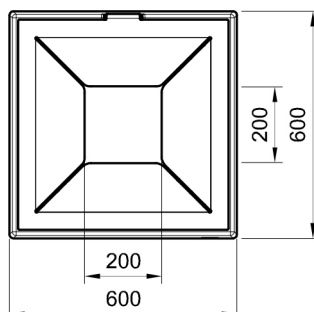
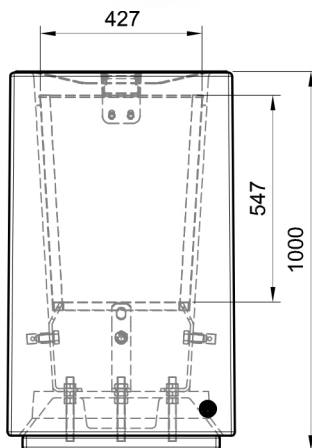

Product:

Rectangular litterbin model “SQUARE”, self-levelling, equipped with a covering. The litter bin is composed by a base and two upper parts. It is equipped with an internal bin, an opening covering to remove the bin and a levelling system.

Dimensions:

length: 600 mm;
width: 600 mm;
height: 1000 mm (variable);
total weight: 490 kg;
capacity: 64 litres.

Material:

The bin can be manufactured using reconstituted natural marble stones or white granite conglomerate. The internal bin, the covering and the levelling stirrups are in galvanised steel.

Reinforcing:

The base is reinforced and fitted with bushes that permit its lifting and levelling. The bin is reinforced and fitted with internal bushes that allow its lifting, and an external bush to support a Bellitalia plate.

Finishing:

The bin surfaces are sandblasted and then covered with a transparent anti-decay coating, or, upon request, with anti-graffiti products. All edges are rounded or made blunt. The covering is treated by a hot dip galvanisation and painted, the internal bin and the levelling stirrups are only treated by a hot dip galvanisation.

Handling:

Use appropriate equipment when handling.

Installation:

Level the base's screws and place the litter bin.