

“PRIMAVERA” Planter

Sheet code: FIPP006

Drawing code: AF01100402

Revision: 23/01/2019

Designer:
Bellitalia Design Department

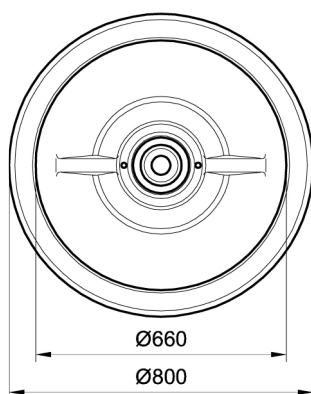
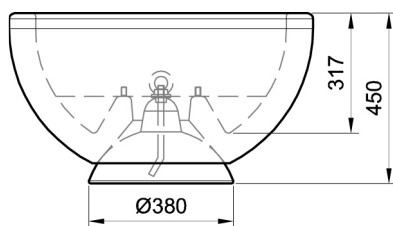

Product: Planter model “PRIMAVERA”, fitted with a **water reserve system** to guarantee the soil the proper humidity level, avoiding the dispersion of internal water. The planter is supported by a base equipped with a **levelling system**, which allows compensation for the slope of the ground by up to a maximum of 10%.

Dimensions: external diameter: 800 mm;
maximum height: 450 mm;
total weight: 135 kg;
capacity: 80 litres.

Material: The planter can be manufactured using reconstituted natural marble stones or white granite conglomerate.

Reinforcing: The planter is reinforced, with internal bushes and eyebolts for lifting.

Finishing: The planter's surface can be polished, to give the product a shiny effect, or bush-hammered, for a rough appearance. The surface is then covered with a transparent anti-decay coating, or, upon request, with anti-graffiti products. All edges are rounded or made blunt.

Handling: Use appropriate equipment when handling, screwing the eyebolts to the bushes.

Installation: Simply place the planter on the flooring and level the upper part by adjusting the eyebolt.